

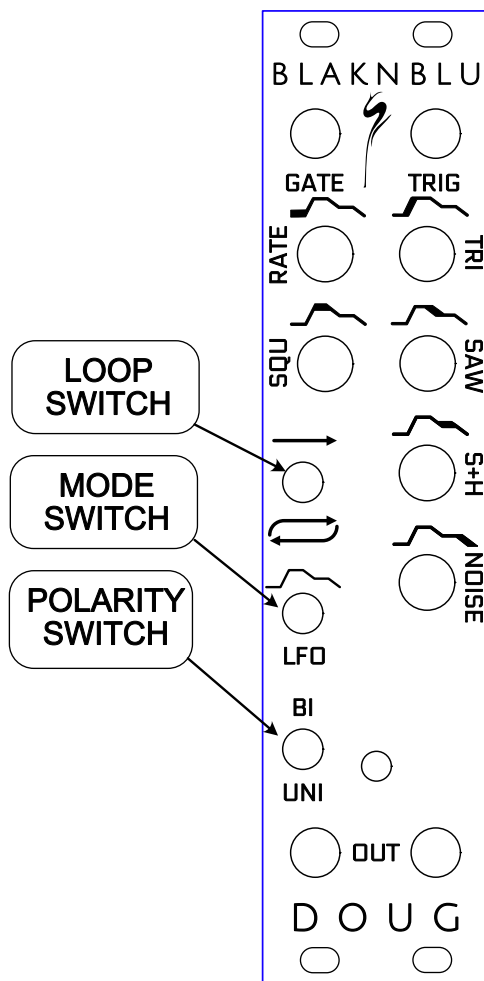

BLAKNBLU

MODULAR SYNTHESIZERS

DOUG



INTRODUCTION

Doug is a flexible modulation source.

It can be an LFO with a whole bunch of output waveforms, all of which can be mixed together (including white noise).

It can also be a six phase envelope generator. You can one-shot the envelope using either a Gate or Trigger input, or it can be looped. Actually you can one shot the LFO too, but we'll get into that later...

INSTALLATION

Be sure to turn off rack power, and unplug from the mains before starting installation. Please observe precautions for static sensitive devices when handling the module.

Doug uses a 16-pin Doepfer standard power cable. Take care to ensure that the cable is fitted the correct way round.

If using the supplied power cable, the plastic lug on the top of the cable connector should fit into the slot in the plastic shroud around the PCB connector.

INPUTS AND OUTPUT

There are two identical outputs at the bottom of the module, so you can, for instance, output your envelope to both a VCA and a VCF without using a mult.

There are two inputs, Gate and Trigger. There are more details on the difference in the sections below but, basically, Trigger only responds to the rising edge of the input signal – it doesn't care when the falling edge happens. Gate, on the other hand, does take account of the falling edge of the input.

LFO OPERATION

For classic LFO operation, set the Mode Switch to LFO and the Loop Switch to loop .

There are five basic waveforms that can be mixed together to form the Output signal.

- Square
- Triangle (or, optionally Sine, depending on the Option Link setting)
- Rising Sawtooth or falling Sawtooth (think whoop-whoop, or pew-pew)
- Sample + Hold
- White Noise



The five level pots control the mix of the five outputs. Sawtooth is a bit unusual in that no Sawtooth signal contributes to the output when the pot is in the centre, 12 o'clock position. Turning the pot to the right (clockwise) adds rising Sawtooth, and tuning it the other way adds falling Sawtooth. The centre position has a 'dead zone', so you don't need to be absolutely at 12 o'clock to get no Sawtooth at all.

Note that the outputs are mixed, rather than simply being summed. If you turn a single output (let's say Triangle) to full, then you get a full-scale Triangle output. As you turn up another waveform (say Sawtooth) then you get a mix between the two – i.e. the amount of Triangle reduces as the Sawtooth increases. This means you can get full scale outputs of any waveform, and adding further waveforms doesn't increase the overall output level, avoiding clipping.

TRIGGER

The Trigger input will hard sync the LFO back to the beginning of a cycle.

SINGLE SHOT

It is possible to run the LFO in Single Shot mode. Simply change the Loop Switch from Loop  to Single Shot . The Trigger input will now cause the LFO to run for a single cycle and then stop. The speed of the cycle is still controlled by the Rate knob. Note that the Noise waveform continues to output... well... noise, whether the LFO is in Loop or Single Shot mode.



The Sample and Hold waveform will generate (and hold) a new random voltage each time the LFO is triggered.







This can be used, for example, to create a variable length pulse from another CV. Turn up the SQUARE output and feed a CV into the Trigger input. The length of the pulse created is controlled by the Rate knob.

BIPOLAR/UNIPOLAR

The Polarity switch selects whether Doug's outputs swing from 0v to +10v (Unipolar) or $\pm 5v$ (Bipolar).

ENVELOPE OPERATION

To operate Doug as a classic Envelope Generator, set the Mode Switch to the envelope icon , the Loop switch to Single Shot  and the Polarity switch to UNI(polar).

Doug's envelopes have six phases. As well as the usual Attack , Decay , Sustain , and Release , there is a Wait phase  which allows you to delay the start of Attack after the Gate or Trigger signals, and a Hold phase  which can introduce a pause at full output after the Attack

phase and before Decay. Below are a couple of pictures showing how Doug responds to the Gate and Trigger inputs.

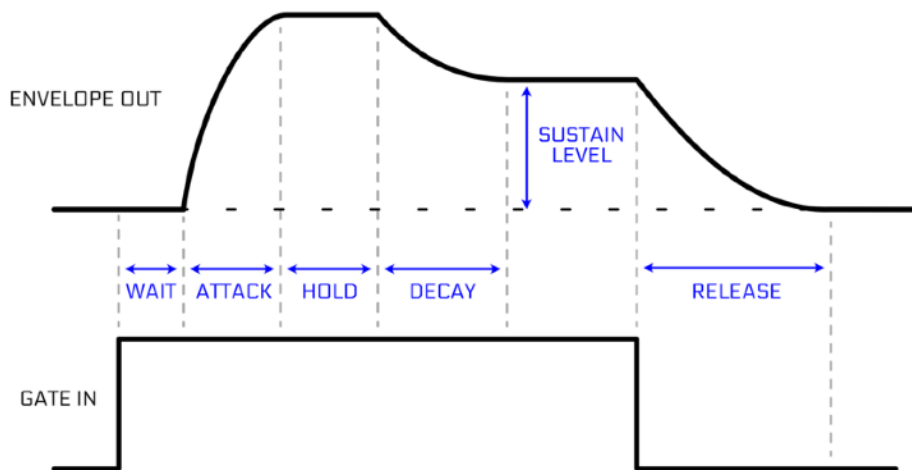

Envelope with Gate Input

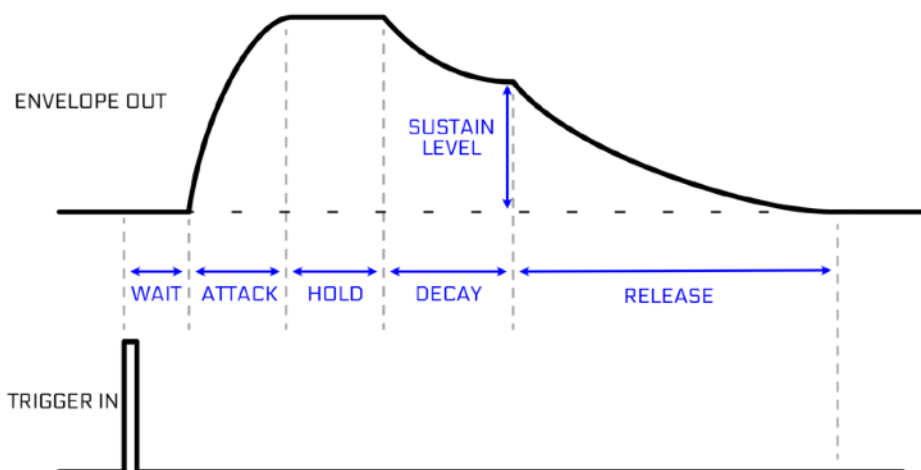

Envelope with Trigger Input

Note that DOUG doesn't really care how long the TRIGGER input signal is – the envelope is started by the rising edge of the signal and just cycles through to the end.

LOOPING

Doug's envelopes can loop, creating interesting cyclic modulations. Just flip the LOOP switch (to LOOP  unsurprisingly).

The TRIGGER input will still force the envelope to restart from the beginning of the WAIT phase.

OPTIONS

Doug's PCB has four option links, in a block labelled J33. The links are fitted in the factory, giving 'normal' operation, but removing the links can enable the following features.

Note that Link 1 is the link furthest from the edge of the PCB and is marked on the PCB silkscreen with <.

| Link Number | Function |
|-------------|--|
| 1 | Link fitted: A rising edge on the Trigger input will cause the envelope to restart from the current output voltage. |
| | Link Removed: A rising edge on the Tigger input will always force the envelope to return to zero (in about 1ms) before restarting. |
| 2 | Link fitted: A rising edge on the Gate input will cause the envelope to restart from the current output voltage. |
| | Link Removed: A rising edge on the Gate input will always force the envelope to return to zero (in about 1ms) before restarting. |
| 3 | Link Fitted: The envelope follows exponential/logarithmic curves. |
| | Link Removed: The envelope rises and falls linearly. |
| 4 | Link Fitted: The Triangle LFO waveform is a triangle. |
| | Link Removed: The Triangle LFO waveform is a sine wave. |

If you have purchased Doug bundled with the 2HP DougSwitches unit, you have front panel control of these options.

Simply remove all the links from the control block (you might want to save them) and connect the 8 way ribbon cable that comes with the switches. Ensure that the red wire on the cable is at the LK1 end of the PCB connector (marked with the with <).

Then connect the other end of the cable to the switch board (if it isn't already), again ensuring that the red wire is at the end of the connector marked with a <, and install both into your rack.

APPENDIX 1 - SPECIFICATIONS

Width: 6HP

Power Consumption:

+12v: < 1mA

-12v: 3mA

+5v: < 1mA

Outputs: $\pm 5V$ (Bipolar mode), 0-10V (Unipolar Mode)

IMPORTANT SAFETY INSTRUCTIONS

Correct disposal of this product:



This symbol indicates that this product must not be disposed of with household waste according to WEEE Directive (2012/19/EU) and your national law. This product should be taken to a collection centre licensed for the recycling of waste electrical and electronic equipment (EEE).

We may change the specifications and operation of our products at any time during their development and production, so we do not guarantee that the information given in this document is accurate or complete.